

Hose Reel Series 893

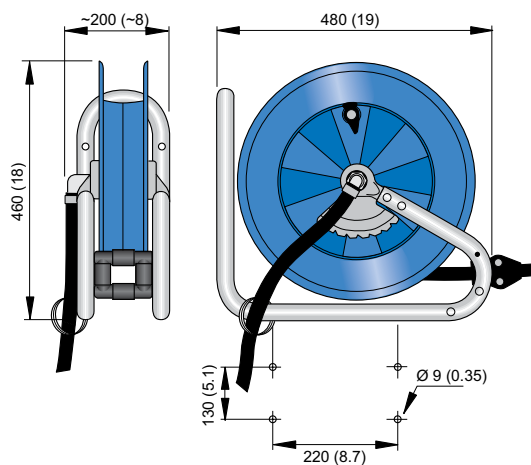

A medium sized hose reel with open design. Versatile and easy to mount in industrial and workshop environments.

- Open design for easy cleaning and servicing
- Unique stand design offers mounting flexibility



Use for	Max. working pressure, MPa (psi)	Distribution hose, Int. Ø, mm (in)	Distribution hose, Length, m	Connection hose, Int. Ø, mm (in)	Connection hose, Length, m	Hose material	Hose type (see page 21)	Weight, kg	Reel with hose Part no.	Reel without hose Part no.
Air/Water	1.5 (220)	10 (3/8)	15	12.5 (1/2)	1	Rubber	B	13-16	30800693	30800393
Air/Water	1.5 (220)	12.5 (1/2)	10	12.5 (1/2)	1	Rubber	B	13-16	30800893	30800793
Water – food grade hose	2.0 (290)	12.5 (1/2)	10	12.5 (1/2)	1	Rubber	E	13-16	30801093	-
HP water	25 (3625)	10 (3/8)	15	10 (3/8)	1	Rubber	G	13-16	30801893	30801793
Oil	7.5 (1090)	12.5 (1/2)	10	12.5 (1/2)	1	Rubber	I	13-16	30801693	30801593
Grease	35 (5075)	6 (1/4)	15	6 (1/4)	1	Rubber	J	13-16	30802693	30802593

Material recycling: 100 %